

Manual

MHS Type-M

Mitsubishi High Speed Serial Interface (MHSSI) Encoder

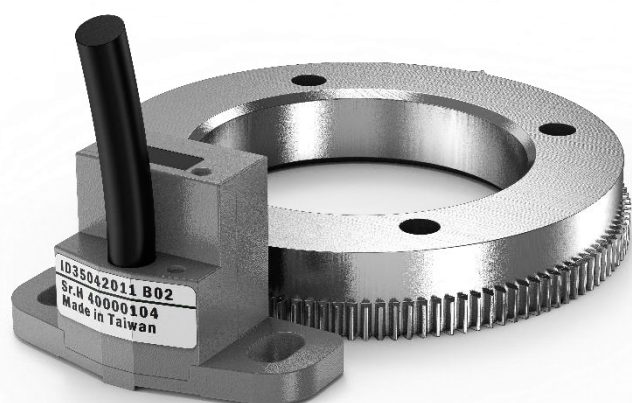

Applications

Speed and position feedback for motorized spindles, CNC lathe, turning/milling machines

General Information

- MHS series is an incremental rotary encoder, the signal is transmitted in the digital form.
- Data transmission interface: Mitsubishi high speed serial interface (MHSSI) 2.5 Mbit/s ; MHS series can be directly connected to Mitsubishi CNC series M800/M80/E80/C80.
- Contactless detection of rotating position and speed can avoid mechanical wear problem.
- Compact design for the installation and application in the narrow space.
- Fully encapsulated packing, protecting rating IP68.
- Is available to provide partial customization.

■ Specification

Specification	MHS-M
Supply voltage Vcc (DCV)	5 V ± 5%
Current consumption (open output)	≤ 90 mA
Data transmission interface	Mitsubishi high speed serial interface (MHSSI)
Data transmission rate	2.5 Mbit/s
Switch-on time	< 0.5 s
Maximum rotational speed	≤ 40000 rpm
Sensing gap	0.15 ± 0.03 mm
Operating temperature	-20°C ~ 85 °C
Protection rating	IP 68
Weight (encoder)	105 g

■ Application

Available on Mitsubishi CNC M800 / M80 / E80 / C80	
Spindle drive	Servo drive
Series <ul style="list-style-type: none"> ■ MDS-E-SP ■ MDS-EH-SP ■ MDS-EJ-SP ■ MDS-EM-SP ■ MDS-EMH-SP 	Series <ul style="list-style-type: none"> ■ MDS-E-Vx ■ MDS-EH-Vx ■ MDS-EJ-Vx ■ MDS-EHG-Vx ■ MDS-EM-Vx ■ MDS-EMH-Vx
Firmware : BND-1501W202	Firmware : BND-1501W201
Firmware : BA or later	Firmware : BA or later

Installation

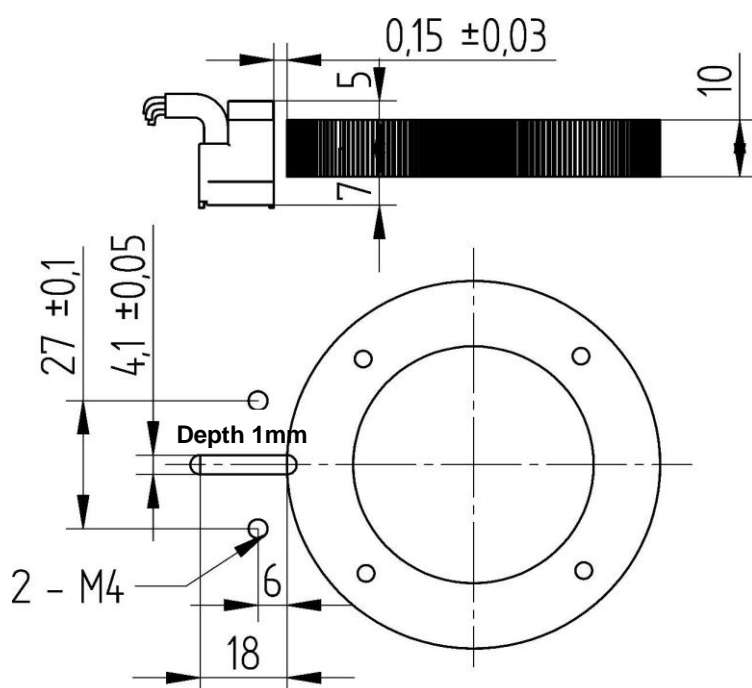

Dimension

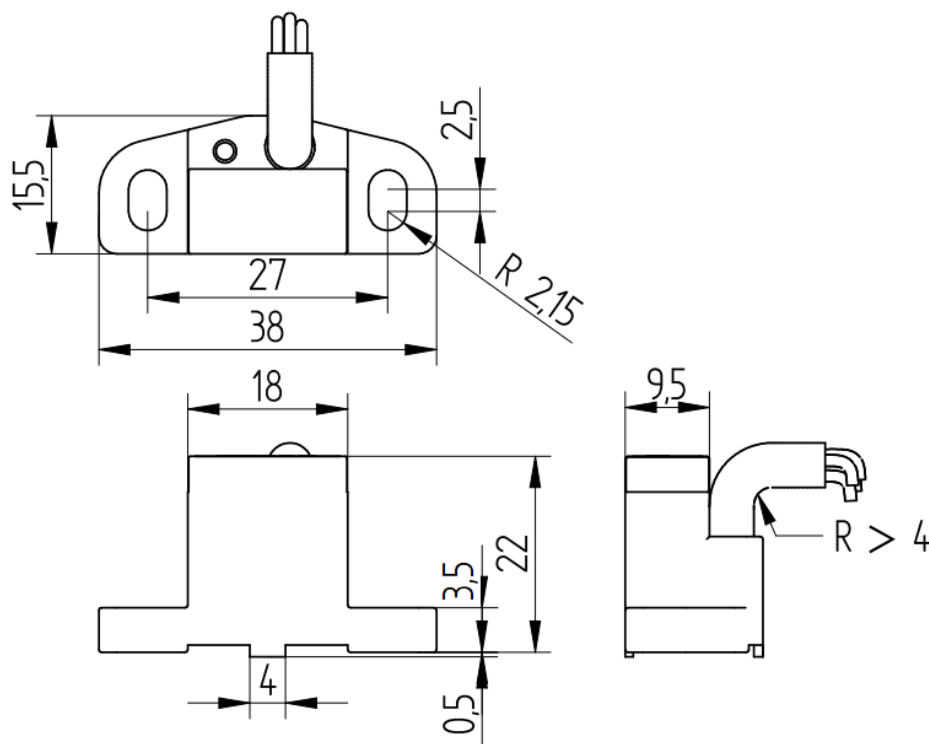

Connector Type

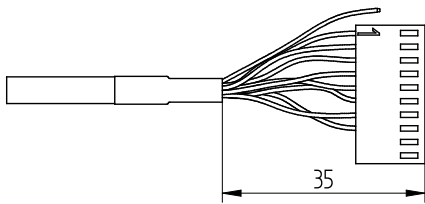
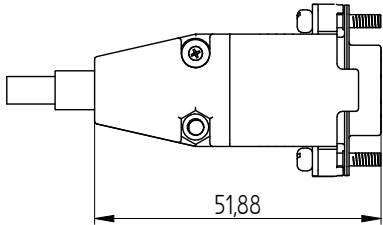
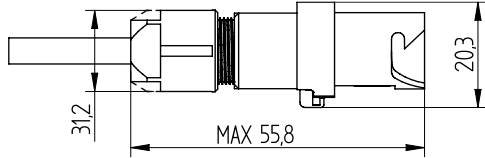
Type	Code	Image
Open-end	N	
D-SUB 9 Pin / Female	D	
JAE 10 Pin / Socket	P	

Pin Definition

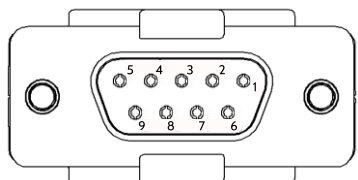
D-SUB - 9 Pin / Female	Pin	Function	Color
	1	-	-
	2	RQ +	green
	3	RQ -	yellow
	4	+5 V	brown
	5	-	-
	6	0 V	white
	7	Data -	pink
	8	Data +	gray
	9	-	-
	Outer casing	Shield	

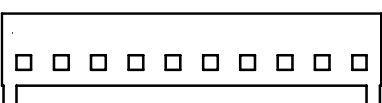
Open-end	Function	Color
	RQ +	green
	RQ -	yellow
	+5 V	brown
	0 V	white
	Data -	pink
	Data +	gray
	Shield	-

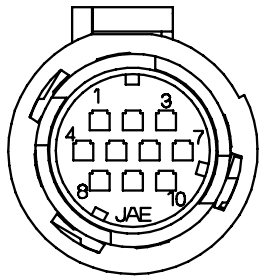
JAE 10 Pin / Socket	Pin	Function	Color
	1	-	-
	2	-	-
	3	RQ +	green
	4	RQ -	yellow
	5	Data +	gray
	6	Data -	pink
	7	+5 V	brown
	8	0 V	white
	9	Shield	-
	10	-	-

■ Gear model

Sensing gear code	
M X XXX - XXX - FS ① ② ③ ④	
①	Module 3 : 0.3, 4 : 0.4, 5 : 0.5
②	Teeth * 64~1024
③	Inner diameter * (mm) : 20~350
④	Reference mark FR : Flag

* Customized available

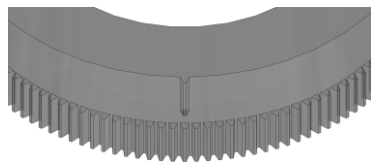
Reference mark	Image
FR	

Encoder model

Encoder type code	
MHS 0X M – XX – XXX – X – X	
① ② ③ ④ ⑤ ⑥	
①	Module 03 : module 0.3 04 : module 0.4 05 : module 0.5
②	Type M: Mini metal case
③	Resolution * 20 bits
④	Induction teeth * 64~1024
⑤	Connectors * N: Open-end D : D-sub 9 Pin P : JAE 10 pin
⑥	Cable length * S : 1 m L : 3 m L4~L20 : 4M~20M

* Customized available