

Manual

IGS Incremental Encoder

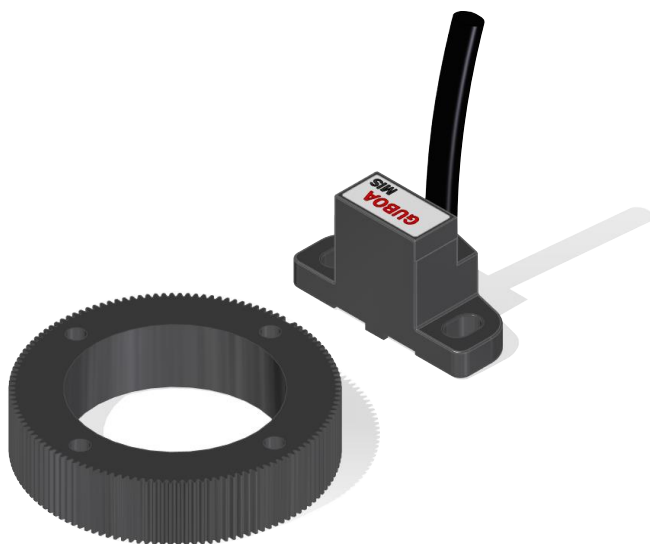

Applications

- Speed and position feedback for high speed spindles, motors, CNC machines

General Information

- Contactless scanning of rotating position and speed.
- Compact design for used in limited space.
- Contact free detection without any mechanical wear problem
- High protecting class IP68.
- Sensing gear wheel from module 0.3 ~ 1.0
- High response, up to 100,000 rpm
- Customized according dimensions

Specification

	1 Vpp (A)	TTL (T)
Power supply Vcc (DCV)	5 V ± 5%	5 V ± 5%
Load current (open output)	≤ 60 mA	≤ 60 mA
VOH (open -output)	N/A	≥ 2.5 V
VOL (open -output)	N/A	≤ 0.5 V
Output signal type	Differential Analog (1 Vpp)	RS 422 (TTL)
Max. Output signal frequency	≥ 150 KHZ	≥ 500 KHZ
Output signal amplitude	≥ 1 Vpp	N/A
A 、 B phase shifting	≤ 90 ± 10°	≤ 90 ± 25°
Sensing gap	0.15 ± 0.03 mm	0.15 ± 0.03 mm
Operating temperature	-20°C ~ 100°C	-20°C ~ 100°C
Protection rating	IP 68	IP 68
Approx weight scanning head (g)	Standard head 30 ± 5% ; Mini head 10 ± 5%	

Signal diagram

1 Vpp (A)	TTL (T)
<p> A+ A- B+ B- Z+ Z- </p>	<p> A+ A- B+ B- Z+ Z- </p> <p>2, 4, 8, 16 interpolation Ex. 4 folds interpolation sensor head with 256T sensor gear : 1024 pulses TTL signal</p>

Dimension & Installation

	Standard (SIS)	Mini (MIS)
Encoder Dimension		
Installation		
Cable Outlet	<p style="text-align: center;">Axial</p>	<p style="text-align: center;">Axial Right (R)</p>

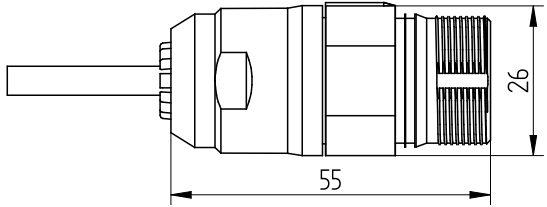
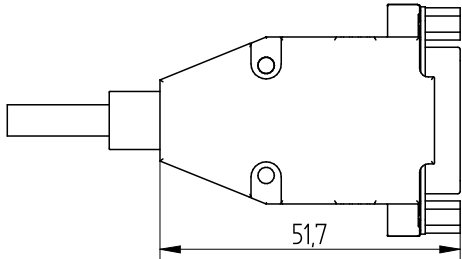
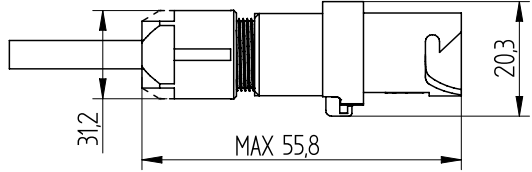
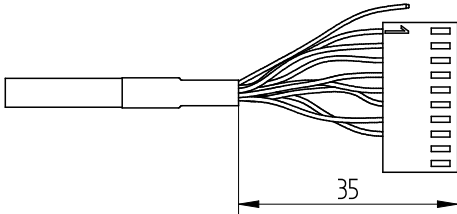
Connector type	code	
<p>M23 12 Pin / 17 Pin</p>	<p>E12 / E17</p>	
<p>D-SUB 15 Pin</p>	<p>D</p>	
<p>JAE 10 Pin</p>	<p>P</p>	
<p>Open-end</p>	<p>N</p>	

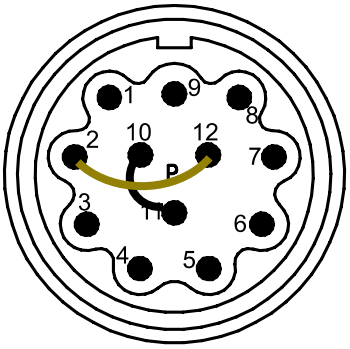
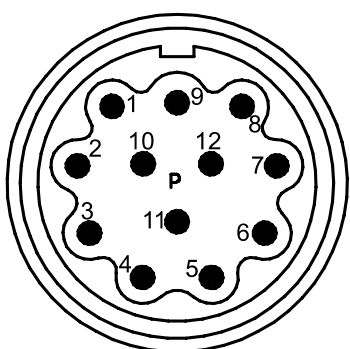
M23 12 Pin				
1Vpp (A)	Pin	Function	Color	TTL (T)
	1	B-	red	
	2	Sensor +	brown	
	3	Z+	grey	
	4	Z-	pink	
	5	A+	green	
	6	A-	yellow	
	7	-		
	8	B+	blue	
	9	-		
	10	GND	white	
	11	Sensor -	white	
	12	V+	brown	

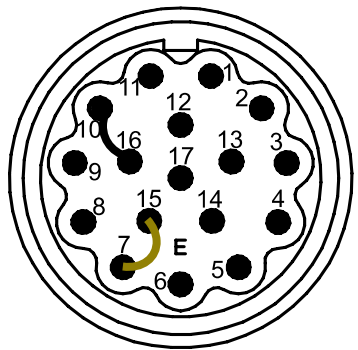
M23 17 Pin	Pin	Function	Color	1Vpp (A)
	1	A	green	A
	2	/A	yellow	/A
	3	Z	grey	Z
	4	-		
	5	-		
	6	-		
	7	GND	white	0V
	8	-		
	9	-		
	10	+ 5V	brown	+ 5V
	11	B	blue	B
	12	/B	red	/B
	13	/Z	pink	/Z
	14	-		
	15	Sensor 0V		
	16	Sensor 5V		
	17	-		

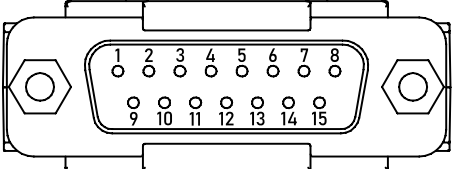
D-SUB 15 Pin	Pin	Function	Color	1Vpp (A)	TTL (T)
	1	Vcc	Brown	Power +5V	Power +5V
	2	GND	White	Power 0V	Power 0V
	3	A+	Green	A+	A+
	4	A-	Yellow	A-	A-
	5	-			
	6	B+	Blue	B+	B+
	7	B-	Red	B-	B-
	8	-			
	9	-			
	10	Z+	Grey	Z+	Z+
	11	-			
	12	Z-	Pink	Z-	Z-
	13	-			
	14	-			
	15	-			

JAE 10pin	Pin	Function	Color	1Vpp (A)	TTL (T)
	1	B+	Green	B+	B+
	2	B-	Yellow	B-	B-
	3	Screen			
	4	V+	Brown	Power +5V	Power +5V
	5	A+	Blue	A+	A+
	6	A-	Red	A-	A-
	7	GND	White	Power 0V	Power 0V
	8	Z+	Grey	Z+	Z+
	9	Z-	pink	Z-	Z-
	10	-			

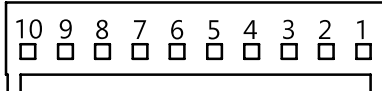
Open-end	Pin	Function	Color	1Vpp (A)	TTL (T)
	1	-			
	2	-			
	3	Z-	Pink	Z-	Z-
	4	Z+	Grey	Z+	Z+
	5	A-	Red	A-	A-
	6	A+	Blue	A+	A+
	7	GND	white	Power 0V	Power 0V
	8	V+	brown	Power +5V	Power +5V
	9	A-	Yellow	A-	A-
	10	A+	green	A+	A+

■ Gear model

Sensing gear code	
M X XXX - XXX - XXX	
① ② ③ ④	
①	Module: 3 : module 0.3 4 : module 0.4 5 : module 0.5
②	Teeth: 128 : 128 teeth 256 : 256 teeth 384 : 384 teeth 512 : 512 teeth
③	Inner diameter (mm) Ex. 125
④	Reference mark: STD : gap FR : flag GH : groove to hill GV : groove to valley

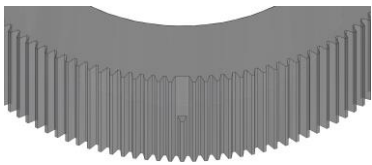
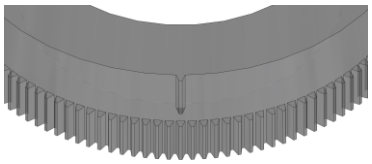
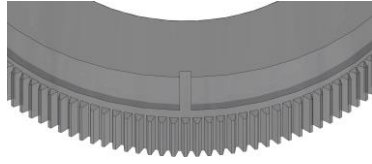
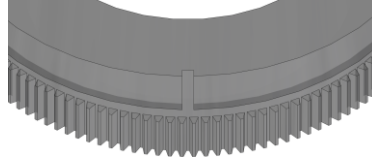
Reference mark	
STD	
FR	
GH	
GV	

Encoder model

Encoder type code	
GS XX - X - XX - XX - X - X - XX-XX - X ① ② ③ ④ ⑤ ⑥ ⑦ ⑧ ⑨	
①	Module 03 : 0.3 04 : 0.4 05 : 0.5
②	Signal type A : 1 Vpp T : TTL / RS422
③	Interpolation 01 : 1 , For 1 Vpp & TTL 02 : 2 , For TTL only 04 : 4 , For TTL only 08 : 8 , For TTL only
④	ZT converter (For 1 Vpp) - : Without F : With ZT converter (For FANUC JYA2 · JYA4)
⑤	Encoder Dimension MI : Mini SI : Standard
⑥	Cable lenth S : 1 m L : 3 m
⑦	Connectors E12 : M23 12 Pin E17 : M23 17 Pin D : D-sub 15 Pin P : JAE 10 pin N : Open end
⑧	Reference mark of gear STD : gap FR : flag GH : groove to hill GV : groove to valley
⑨	Cable outlet - : Axial R : Right